

# 74AHC132; 74AHCT132

Quad 2-input NAND Schmitt trigger

Rev. 04 — 7 February 2005

Product data sheet

## 1. General description

The 74AHC132; 74AHCT132 is a high-speed Si-gate CMOS device and is pin compatible with Low-power Schottky TTL (LSTTL). The device is specified in compliance with JEDEC standard No. 7A.

The 74AHC132; 74AHCT132 contains four 2-input NAND gates which accept standard input signals. They are capable of transforming slowly changing input signals into sharply defined, jitter free output signals.

The gate switches at different points for positive-going and negative-going signals. The difference between the positive voltage  $V_{T+}$  and the negative  $V_{T-}$  is defined as the hysteresis voltage  $V_H$ .

## 2. Features

- Balanced propagation delays
- Inputs accepts voltages higher than  $V_{CC}$
- For 74AHC132 only: operates with CMOS input levels
- For 74AHCT132 only: operates with TTL input levels
- ESD protection:
  - ◆ HBM EIA/JESD22-A114-B exceeds 2000 V
  - ◆ MM EIA/JESD22-A115-A exceeds 200 V
  - ◆ CDM EIA/JESD22-C101 exceeds 1000 V
- Specified from  $-40\text{ }^{\circ}\text{C}$  to  $+85\text{ }^{\circ}\text{C}$  and from  $-40\text{ }^{\circ}\text{C}$  to  $+125\text{ }^{\circ}\text{C}$

## 3. Quick reference data

**Table 1: Quick reference data**

$GND = 0\text{ V}$ ;  $T_{amb} = 25\text{ }^{\circ}\text{C}$ ;  $t_r = t_f \leq 3.0\text{ ns}$ .

Symbol	Parameter	Conditions	Min	Typ	Max	Unit
<b>Type 74AHC132</b>						
$t_{PHL}$ , $t_{PLH}$	propagation delay nA to nY	$C_L = 15\text{ pF}$ ; $V_{CC} = 5\text{ V}$	-	3.3	-	ns
$C_I$	input capacitance	$V_I = V_{CC}$ or GND	-	3.0	-	pF
$C_O$	output capacitance		-	4.0	-	pF
$C_{PD}$	power dissipation capacitance	$C_L = 50\text{ pF}$ ; $f = 1\text{ MHz}$	<a href="#">[1]</a> <a href="#">[2]</a>	11	-	pF

**PHILIPS**

**Table 1: Quick reference data ...continued** $GND = 0\text{ V}$ ;  $T_{amb} = 25\text{ °C}$ ;  $t_r = t_f \leq 3.0\text{ ns}$ .

Symbol	Parameter	Conditions	Min	Typ	Max	Unit
<b>Type 74AHCT132</b>						
$t_{PHL}$ , $t_{PLH}$	propagation delay nA to nY	$C_L = 15\text{ pF}$ ; $V_{CC} = 5\text{ V}$	-	3.5	-	ns
$C_I$	input capacitance	$V_I = V_{CC}$ or GND	-	3.0	-	pF
$C_O$	output capacitance		-	4.0	-	pF
$C_{PD}$	power dissipation capacitance	$C_L = 50\text{ pF}$ ; $f = 1\text{ MHz}$	[1][2]	14	-	pF

[1]  $C_{PD}$  is used to determine the dynamic power dissipation ( $P_D$  in  $\mu\text{W}$ ).

$$P_D = C_{PD} \times V_{CC}^2 \times f_i \times N + \sum (C_L \times V_{CC}^2 \times f_o) \text{ where:}$$

$f_i$  = input frequency in MHz;

$f_o$  = output frequency in MHz;

$C_L$  = output load capacitance in pF;

$V_{CC}$  = supply voltage in V;

$N$  = number of inputs switching;

$\sum (C_L \times V_{CC}^2 \times f_o)$  = sum of outputs.

[2] The condition is  $V_I = GND$  to  $V_{CC}$ .

## 4. Ordering information

**Table 2: Ordering information**

Type number	Package			
	Temperature range	Name	Description	Version
74AHC132D	-40 °C to +125 °C	SO14	plastic small outline package; 14 leads; body width 3.9 mm	SOT108-1
74AHC132PW	-40 °C to +125 °C	TSSOP14	plastic thin shrink small outline package; 14 leads; body width 4.4 mm	SOT402-1
74AHC132BQ	-40 °C to +125 °C	DHVQFN14	plastic dual in-line compatible thermal enhanced very thin quad flat package; no leads; 14 terminals; body 2.5 × 3 × 0.85 mm	SOT762-1
74AHCT132D	-40 °C to +125 °C	SO14	plastic small outline package; 14 leads; body width 3.9 mm	SOT108-1
74AHCT132PW	-40 °C to +125 °C	TSSOP14	plastic thin shrink small outline package; 14 leads; body width 4.4 mm	SOT402-1
74AHCT132BQ	-40 °C to +125 °C	DHVQFN14	plastic dual in-line compatible thermal enhanced very thin quad flat package; no leads; 14 terminals; body 2.5 × 3 × 0.85 mm	SOT762-1

## 5. Functional diagram

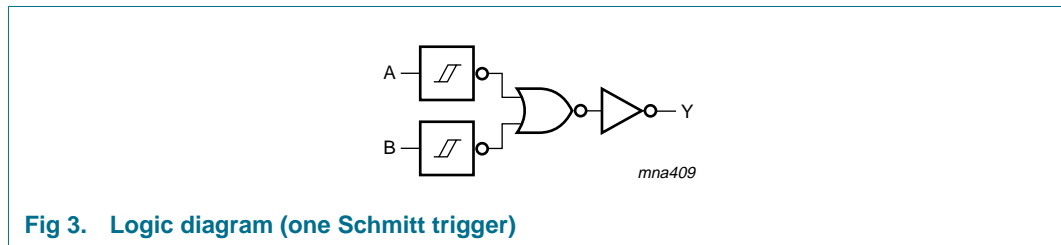
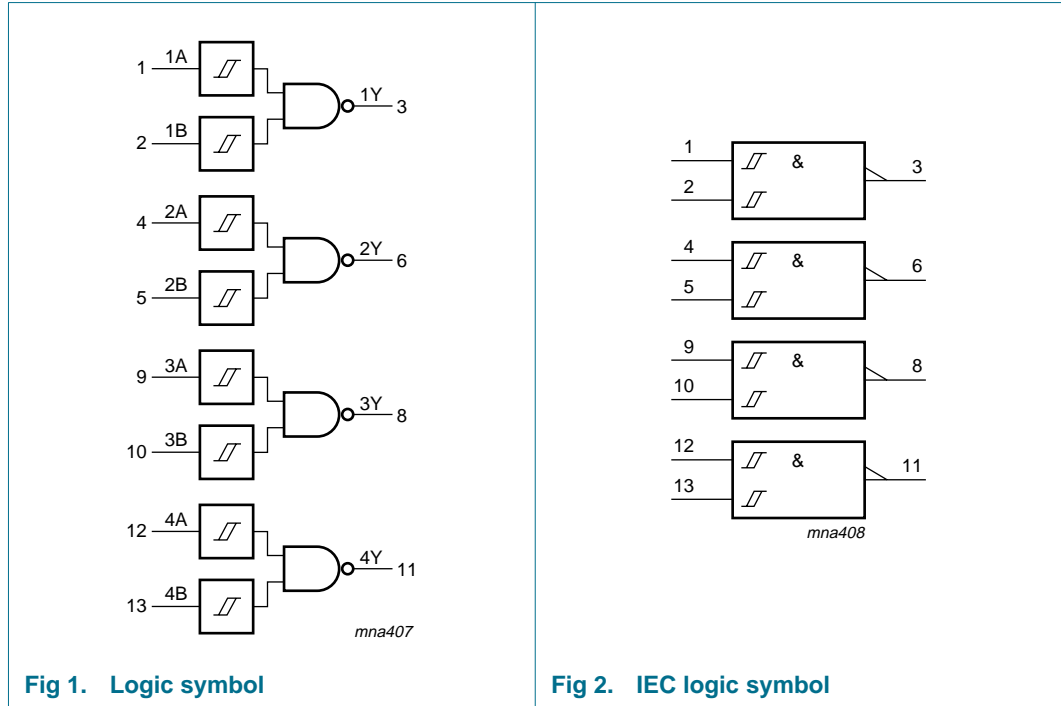

## 6. Pinning information

### 6.1 Pinning

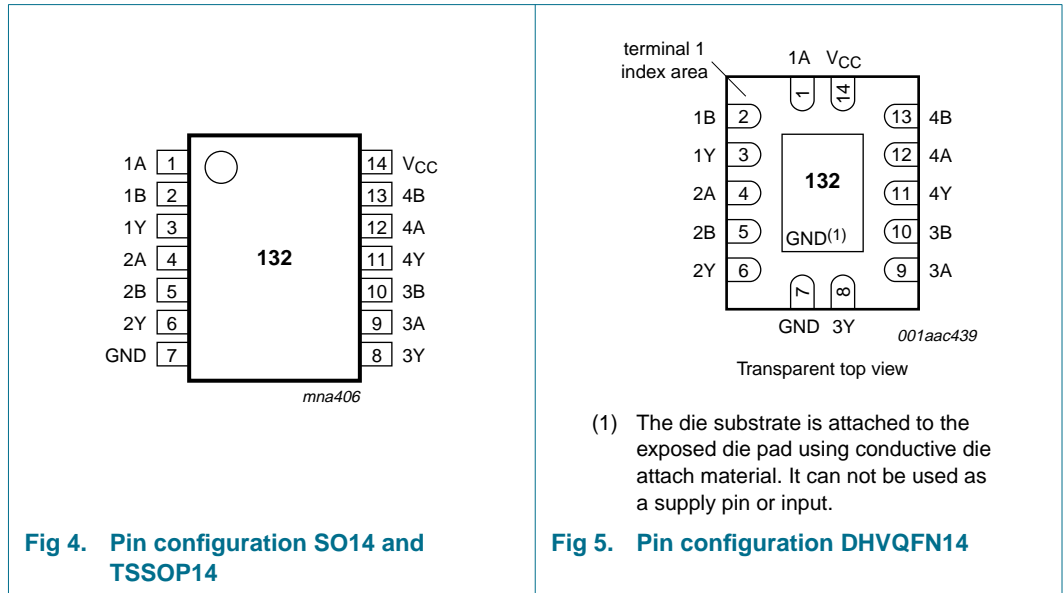

### 6.2 Pin description

Table 3: Pin description

Symbol	Pin	Description
1A	1	1 data input A
1B	2	1 data input B
1Y	3	1 data output Y
2A	4	2 data input A
2B	5	2 data input B
2Y	6	2 data output Y
GND	7	ground (0 V)
3Y	8	3 data output Y
3A	9	3 data input A
3B	10	3 data input B
4Y	11	4 data output Y
4A	12	4 data input A
4B	13	4 data input B
V <sub>CC</sub>	14	supply voltage

## 7. Functional description

### 7.1 Function table

Table 4: Function table <sup>[1]</sup>

Input		Output
nA	nB	nY
L	L	H
L	H	H
H	L	H
H	H	L

[1] H = HIGH voltage level;  
L = LOW voltage level.

## 8. Limiting values

Table 5: Limiting values

In accordance with the Absolute Maximum Rating System (IEC 60134). Voltages are referenced to GND (ground = 0 V).

Symbol	Parameter	Conditions	Min	Max	Unit
$V_{CC}$	supply voltage		-0.5	+7.0	V
$V_I$	input voltage range		-0.5	+7.0	V
$I_{IK}$	input diode current	$V_I < -0.5$ V	<sup>[1]</sup> -	-20	mA
$I_{OK}$	output diode current	$V_O < -0.5$ V or $V_O > V_{CC} + 0.5$ V	<sup>[1]</sup> -	±20	mA
$I_O$	output source or sink current	$V_O > -0.5$ V or $V_O < V_{CC} + 0.5$ V	-	±25	mA
$I_{CC}, I_{GND}$	$V_{CC}$ or GND current		-	±75	mA
$T_{stg}$	storage temperature		-65	+150	°C
$P_{tot}$	total power dissipation	$T_{amb} = -40$ °C to +125 °C	<sup>[2]</sup> -	500	mW

[1] The input and output voltage ratings may be exceeded if the input and output current ratings are observed.

[2] For SO14 packages:  $P_{tot}$  derates linearly with 8 mW/K above 70 °C.

For TSSOP14 packages:  $P_{tot}$  derates linearly with 5.5 mW/K above 60 °C.

For DHVQFN14 packages:  $P_{tot}$  derates linearly with 4.5 mW/K above 60 °C.

## 9. Recommended operating conditions

Table 6: Recommended operating conditions

Symbol	Parameter	Conditions	Min	Typ	Max	Unit
<b>Type74AHC132</b>						
$V_{CC}$	supply voltage		2.0	5.0	5.5	V
$V_I$	input voltage		0	-	5.5	V
$V_O$	output voltage		0	-	$V_{CC}$	V
$T_{amb}$	ambient temperature		-40	+25	+125	°C

Table 6: Recommended operating conditions ...continued

Symbol	Parameter	Conditions	Min	Typ	Max	Unit
<b>Type 74AHCT132</b>						
$V_{CC}$	supply voltage		4.5	5.0	5.5	V
$V_I$	input voltage		0	-	5.5	V
$V_O$	output voltage		0	-	$V_{CC}$	V
$T_{amb}$	ambient temperature		-40	+25	+125	°C

## 10. Static characteristics

Table 7: Static characteristics type 74AHC132

At recommended operating conditions; voltages are referenced to GND (ground = 0 V).

Symbol	Parameter	Conditions	Min	Typ	Max	Unit
<b><math>T_{amb} = 25\text{ °C}</math></b>						
$V_{T+}$	positive-going threshold	$V_{CC} = 3.0\text{ V}$	-	-	2.2	V
		$V_{CC} = 4.5\text{ V}$	-	-	3.15	V
		$V_{CC} = 5.5\text{ V}$	-	-	3.85	V
$V_{T-}$	negative-going threshold	$V_{CC} = 3.0\text{ V}$	0.9	-	-	V
		$V_{CC} = 4.5\text{ V}$	1.35	-	-	V
		$V_{CC} = 5.5\text{ V}$	1.65	-	-	V
$V_H$	hysteresis ( $V_{T+} - V_{T-}$ )	$V_{CC} = 3.0\text{ V}$	0.3	-	1.2	V
		$V_{CC} = 4.5\text{ V}$	0.4	-	1.4	V
		$V_{CC} = 5.5\text{ V}$	0.5	-	1.6	V
$V_{OH}$	HIGH-level output voltage	$V_I = V_{IH}$ or $V_{IL}$				
		$I_O = -50\text{ }\mu\text{A}$ ; $V_{CC} = 2.0\text{ V}$	1.9	2.0	-	V
		$I_O = -50\text{ }\mu\text{A}$ ; $V_{CC} = 3.0\text{ V}$	2.9	3.0	-	V
		$I_O = -50\text{ }\mu\text{A}$ ; $V_{CC} = 4.5\text{ V}$	4.4	4.5	-	V
		$I_O = -4.0\text{ mA}$ ; $V_{CC} = 3.0\text{ V}$	2.58	-	-	V
$V_{OL}$	LOW-level output voltage	$V_I = V_{IH}$ or $V_{IL}$				
		$I_O = 50\text{ }\mu\text{A}$ ; $V_{CC} = 2.0\text{ V}$	-	0	0.1	V
		$I_O = 50\text{ }\mu\text{A}$ ; $V_{CC} = 3.0\text{ V}$	-	0	0.1	V
		$I_O = 50\text{ }\mu\text{A}$ ; $V_{CC} = 4.5\text{ V}$	-	0	0.1	V
		$I_O = 4.0\text{ mA}$ ; $V_{CC} = 3.0\text{ V}$	-	-	0.36	V
		$I_O = 8.0\text{ mA}$ ; $V_{CC} = 4.5\text{ V}$	-	-	0.36	V
$I_{LI}$	input leakage current	$V_I = V_{CC}$ or GND; $V_{CC} = 5.5\text{ V}$	-	-	0.1	$\mu\text{A}$
$I_{CC}$	quiescent supply current	$V_I = V_{CC}$ or GND; $I_O = 0\text{ A}$ ; $V_{CC} = 5.5\text{ V}$	-	-	2.0	$\mu\text{A}$
$C_I$	input capacitance	$V_I = V_{CC}$ or GND	-	3.0	10	pF
$C_O$	output capacitance		-	4.0	-	pF
<b><math>T_{amb} = -40\text{ °C to }+85\text{ °C}</math></b>						
$V_{T+}$	positive-going threshold	$V_{CC} = 3.0\text{ V}$	-	-	2.2	V
		$V_{CC} = 4.5\text{ V}$	-	-	3.15	V
		$V_{CC} = 5.5\text{ V}$	-	-	3.85	V

**Table 7: Static characteristics type 74AHC132 ...continued**

At recommended operating conditions; voltages are referenced to GND (ground = 0 V).

Symbol	Parameter	Conditions	Min	Typ	Max	Unit
$V_{T-}$	negative-going threshold	$V_{CC} = 3.0\text{ V}$	0.9	-	-	V
		$V_{CC} = 4.5\text{ V}$	1.35	-	-	V
		$V_{CC} = 5.5\text{ V}$	1.65	-	-	V
$V_H$	hysteresis ( $V_{T+} - V_{T-}$ )	$V_{CC} = 3.0\text{ V}$	0.3	-	1.2	V
		$V_{CC} = 4.5\text{ V}$	0.4	-	1.4	V
		$V_{CC} = 5.5\text{ V}$	0.5	-	1.6	V
$V_{OH}$	HIGH-level output voltage	$V_I = V_{IH}$ or $V_{IL}$				
		$I_O = -50\text{ }\mu\text{A}$ ; $V_{CC} = 2.0\text{ V}$	1.9	-	2.2	V
		$I_O = -50\text{ }\mu\text{A}$ ; $V_{CC} = 3.0\text{ V}$	2.9	-	3.15	V
		$I_O = -50\text{ }\mu\text{A}$ ; $V_{CC} = 4.5\text{ V}$	4.4	-	3.85	V
		$I_O = -4.0\text{ mA}$ ; $V_{CC} = 3.0\text{ V}$	2.48	-	-	V
$V_{OL}$	LOW-level output voltage	$V_I = V_{IH}$ or $V_{IL}$				
		$I_O = 50\text{ }\mu\text{A}$ ; $V_{CC} = 2.0\text{ V}$	-	-	0.1	V
		$I_O = 50\text{ }\mu\text{A}$ ; $V_{CC} = 3.0\text{ V}$	-	-	0.1	V
		$I_O = 50\text{ }\mu\text{A}$ ; $V_{CC} = 4.5\text{ V}$	-	-	0.1	V
		$I_O = 4.0\text{ mA}$ ; $V_{CC} = 3.0\text{ V}$	-	-	0.44	V
$I_{LI}$	input leakage current	$V_I = V_{CC}$ or GND; $V_{CC} = 5.5\text{ V}$	-	-	1.0	$\mu\text{A}$
		$V_I = V_{CC}$ or GND; $I_O = 0\text{ A}$ ; $V_{CC} = 5.5\text{ V}$	-	-	20	$\mu\text{A}$
$C_I$	input capacitance		-	-	10	pF
<b><math>T_{amb} = -40\text{ }^\circ\text{C}</math> to <math>+125\text{ }^\circ\text{C}</math></b>						
$V_{T+}$	positive-going threshold	$V_{CC} = 3.0\text{ V}$	-	-	2.2	V
		$V_{CC} = 4.5\text{ V}$	-	-	3.15	V
		$V_{CC} = 5.5\text{ V}$	-	-	3.85	V
$V_{T-}$	negative-going threshold	$V_{CC} = 3.0\text{ V}$	0.9	-	-	V
		$V_{CC} = 4.5\text{ V}$	1.35	-	-	V
		$V_{CC} = 5.5\text{ V}$	1.65	-	-	V
$V_H$	hysteresis ( $V_{T+} - V_{T-}$ )	$V_{CC} = 3.0\text{ V}$	0.25	-	1.2	V
		$V_{CC} = 4.5\text{ V}$	0.35	-	1.4	V
		$V_{CC} = 5.5\text{ V}$	0.45	-	1.6	V
$V_{OH}$	HIGH-level output voltage	$V_I = V_{IH}$ or $V_{IL}$				
		$I_O = -50\text{ }\mu\text{A}$ ; $V_{CC} = 2.0\text{ V}$	1.9	-	-	V
		$I_O = -50\text{ }\mu\text{A}$ ; $V_{CC} = 3.0\text{ V}$	2.9	-	-	V
		$I_O = -50\text{ }\mu\text{A}$ ; $V_{CC} = 4.5\text{ V}$	4.4	-	-	V
		$I_O = -4.0\text{ mA}$ ; $V_{CC} = 3.0\text{ V}$	2.40	-	-	V
$I_{OH}$	HIGH-level output current	$I_O = -8.0\text{ mA}$ ; $V_{CC} = 4.5\text{ V}$	3.7	-	-	V

**Table 7: Static characteristics type 74AHC132 ...continued**

At recommended operating conditions; voltages are referenced to GND (ground = 0 V).

Symbol	Parameter	Conditions	Min	Typ	Max	Unit
V <sub>OL</sub>	LOW-level output voltage	V <sub>I</sub> = V <sub>IH</sub> or V <sub>IL</sub>				
		I <sub>O</sub> = 50 μA; V <sub>CC</sub> = 2.0 V	-	-	0.1	V
		I <sub>O</sub> = 50 μA; V <sub>CC</sub> = 3.0 V	-	-	0.1	V
		I <sub>O</sub> = 50 μA; V <sub>CC</sub> = 4.5 V	-	-	0.1	V
		I <sub>O</sub> = 4.0 mA; V <sub>CC</sub> = 3.0 V	-	-	0.55	V
		I <sub>O</sub> = 8.0 mA; V <sub>CC</sub> = 4.5 V	-	-	0.55	V
I <sub>LI</sub>	input leakage current	V <sub>I</sub> = V <sub>CC</sub> or GND; V <sub>CC</sub> = 5.5 V	-	-	2.0	μA
I <sub>CC</sub>	quiescent supply current	V <sub>I</sub> = V <sub>CC</sub> or GND; I <sub>O</sub> = 0 A; V <sub>CC</sub> = 5.5 V	-	-	40	μA
C <sub>I</sub>	input capacitance		-	-	10	pF

**Table 8: Static characteristics type 74AHCT132**

At recommended operating conditions; voltages are referenced to GND (ground = 0 V).

Symbol	Parameter	Conditions	Min	Typ	Max	Unit
<b>T<sub>amb</sub> = 25 °C</b>						
V <sub>T+</sub>	positive-going threshold	V <sub>CC</sub> = 4.5 V	-	-	1.9	V
		V <sub>CC</sub> = 5.5 V	-	-	2.1	V
V <sub>T-</sub>	negative-going threshold	V <sub>CC</sub> = 4.5 V	0.5	-	-	V
		V <sub>CC</sub> = 5.5 V	0.6	-	-	V
V <sub>H</sub>	hysteresis (V <sub>T+</sub> - V <sub>T-</sub> )	V <sub>CC</sub> = 4.5 V	0.3	-	1.4	V
		V <sub>CC</sub> = 5.5 V	0.3	-	1.5	V
V <sub>OH</sub>	HIGH-level output voltage	V <sub>I</sub> = V <sub>IH</sub> or V <sub>IL</sub>				
		I <sub>O</sub> = -50 μA; V <sub>CC</sub> = 4.5 V	4.4	4.5	-	V
		I <sub>O</sub> = -8.0 mA; V <sub>CC</sub> = 4.5 V	3.94	-	-	V
V <sub>OL</sub>	LOW-level output voltage	V <sub>I</sub> = V <sub>IH</sub> or V <sub>IL</sub>				
		I <sub>O</sub> = 50 μA; V <sub>CC</sub> = 4.5 V	-	0	0.1	V
		I <sub>O</sub> = 8.0 mA; V <sub>CC</sub> = 4.5 V	-	-	0.36	V
I <sub>LI</sub>	input leakage current	V <sub>I</sub> = V <sub>CC</sub> or GND; V <sub>CC</sub> = 5.5 V	-	-	0.1	μA
I <sub>CC</sub>	quiescent supply current	V <sub>I</sub> = V <sub>CC</sub> or GND; I <sub>O</sub> = 0 A; V <sub>CC</sub> = 5.5 V	-	-	2.0	μA
ΔI <sub>CC</sub>	additional quiescent supply current per input pin	V <sub>I</sub> = V <sub>CC</sub> - 2.1 V and other inputs at V <sub>CC</sub> or GND; I <sub>O</sub> = 0 A; V <sub>CC</sub> = 4.5 V to 5.5 V	-	-	1.35	mA
C <sub>I</sub>	input capacitance	V <sub>I</sub> = V <sub>CC</sub> or GND	-	3.0	10	pF
C <sub>O</sub>	output capacitance		-	4.0	-	pF
<b>T<sub>amb</sub> = -40 °C to +85 °C</b>						
V <sub>T+</sub>	positive-going threshold	V <sub>CC</sub> = 4.5 V	-	-	1.9	V
		V <sub>CC</sub> = 5.5 V	-	-	2.1	V
V <sub>T-</sub>	negative-going threshold	V <sub>CC</sub> = 4.5 V	0.5	-	-	V
		V <sub>CC</sub> = 5.5 V	0.6	-	-	V
V <sub>H</sub>	hysteresis (V <sub>T+</sub> - V <sub>T-</sub> )	V <sub>CC</sub> = 4.5 V	0.3	-	1.4	V
		V <sub>CC</sub> = 5.5 V	0.3	-	1.5	V



**Table 8: Static characteristics type 74AHCT132 ...continued**

At recommended operating conditions; voltages are referenced to GND (ground = 0 V).

Symbol	Parameter	Conditions	Min	Typ	Max	Unit
V <sub>OH</sub>	HIGH-level output voltage	V <sub>I</sub> = V <sub>IH</sub> or V <sub>IL</sub>				
		I <sub>O</sub> = -50 µA; V <sub>CC</sub> = 4.5 V	4.4	-	-	V
		I <sub>O</sub> = -8.0 mA; V <sub>CC</sub> = 4.5 V	3.8	-	-	V
V <sub>OL</sub>	LOW-level output voltage	V <sub>I</sub> = V <sub>IH</sub> or V <sub>IL</sub>				
		I <sub>O</sub> = 50 µA; V <sub>CC</sub> = 4.5 V	-	-	0.1	V
		I <sub>O</sub> = 8.0 mA; V <sub>CC</sub> = 4.5 V	-	-	0.44	V
I <sub>LI</sub>	input leakage current	V <sub>I</sub> = V <sub>CC</sub> or GND; V <sub>CC</sub> = 5.5 V	-	-	1.0	µA
I <sub>CC</sub>	quiescent supply current	V <sub>I</sub> = V <sub>CC</sub> or GND; I <sub>O</sub> = 0 A; V <sub>CC</sub> = 5.5 V	-	-	20	µA
ΔI <sub>CC</sub>	additional quiescent supply current per input pin	V <sub>I</sub> = V <sub>CC</sub> - 2.1 V and other inputs at V <sub>CC</sub> or GND; I <sub>O</sub> = 0 A; V <sub>CC</sub> = 4.5 V to 5.5 V	-	-	1.5	mA
C <sub>I</sub>	input capacitance		-	-	10	pF
<b>T<sub>amb</sub> = -40 °C to +125 °C</b>						
V <sub>T+</sub>	positive-going threshold	V <sub>CC</sub> = 4.5 V	-	-	1.9	V
		V <sub>CC</sub> = 5.5 V	-	-	2.1	V
V <sub>T-</sub>	negative-going threshold	V <sub>CC</sub> = 4.5 V	0.5	-	-	V
		V <sub>CC</sub> = 5.5 V	0.6	-	-	V
V <sub>H</sub>	hysteresis (V <sub>T+</sub> - V <sub>T-</sub> )	V <sub>CC</sub> = 4.5 V	0.3	-	1.4	V
		V <sub>CC</sub> = 5.5 V	0.3	-	1.5	V
V <sub>OH</sub>	HIGH-level output voltage	V <sub>I</sub> = V <sub>IH</sub> or V <sub>IL</sub>				
		I <sub>O</sub> = -50 µA; V <sub>CC</sub> = 4.5 V	4.4	-	-	V
		I <sub>O</sub> = -8.0 mA; V <sub>CC</sub> = 4.5 V	3.7	-	-	V
V <sub>OL</sub>	LOW-level output voltage	V <sub>I</sub> = V <sub>IH</sub> or V <sub>IL</sub>				
		I <sub>O</sub> = 50 µA; V <sub>CC</sub> = 4.5 V	-	-	0.1	V
		I <sub>O</sub> = 8.0 mA; V <sub>CC</sub> = 4.5 V	-	-	0.55	V
I <sub>LI</sub>	input leakage current	V <sub>I</sub> = V <sub>CC</sub> or GND; V <sub>CC</sub> = 5.5 V	-	-	2.0	µA
I <sub>CC</sub>	quiescent supply current	V <sub>I</sub> = V <sub>CC</sub> or GND; I <sub>O</sub> = 0 A; V <sub>CC</sub> = 5.5 V	-	-	40	µA
ΔI <sub>CC</sub>	additional quiescent supply current per input pin	V <sub>I</sub> = V <sub>CC</sub> - 2.1 V and other inputs at V <sub>CC</sub> or GND; I <sub>O</sub> = 0 A; V <sub>CC</sub> = 4.5 V to 5.5 V	-	-	1.5	mA
C <sub>I</sub>	input capacitance		-	-	10	pF

## 11. Dynamic characteristics

**Table 9: Dynamic characteristics type 74AHC132**

$GND = 0\text{ V}$ ;  $t_r = t_f \leq 3.0\text{ ns}$ ; for test circuit see [Figure 7](#).

Symbol	Parameter	Conditions	Min	Typ	Max	Unit	
<b><math>T_{amb} = 25\text{ °C}</math></b>							
$t_{PHL}$ , $t_{PLH}$	propagation delay nA, nB to nY	$V_{CC} = 3.0\text{ V to }3.6\text{ V}$ ; see <a href="#">Figure 6</a>	[1]				
		$C_L = 15\text{ pF}$	-	4.4	11.9	ns	
		$C_L = 50\text{ pF}$	-	6.2	15.4	ns	
		$V_{CC} = 4.5\text{ V to }5.5\text{ V}$ ; see <a href="#">Figure 6</a>	[2]				
		$C_L = 15\text{ pF}$	-	3.3	7.7	ns	
		$C_L = 50\text{ pF}$	-	4.7	9.7	ns	
$C_{PD}$	power dissipation capacitance	$C_L = 50\text{ pF}$ ; $f = 1\text{ MHz}$	[3][4]	-	11	-	pF
<b><math>T_{amb} = -40\text{ °C to }+85\text{ °C}</math></b>							
$t_{PHL}$ , $t_{PLH}$	propagation delay nA, nB to nY	$V_{CC} = 3.0\text{ V to }3.6\text{ V}$ ; see <a href="#">Figure 6</a>					
		$C_L = 15\text{ pF}$	1.0	-	14.0	ns	
		$C_L = 50\text{ pF}$	1.0	-	17.5	ns	
		$V_{CC} = 4.5\text{ V to }5.5\text{ V}$ ; see <a href="#">Figure 6</a>					
		$C_L = 15\text{ pF}$	1.0	-	9.0	ns	
		$C_L = 50\text{ pF}$	1.0	-	11.0	ns	
<b><math>T_{amb} = -40\text{ °C to }+125\text{ °C}</math></b>							
$t_{PHL}$ , $t_{PLH}$	propagation delay nA, nB to nY	$V_{CC} = 3.0\text{ V to }3.6\text{ V}$ ; see <a href="#">Figure 6</a>					
		$C_L = 15\text{ pF}$	1.0	-	15.0	ns	
		$C_L = 50\text{ pF}$	1.0	-	19.5	ns	
		$V_{CC} = 4.5\text{ V to }5.5\text{ V}$ ; see <a href="#">Figure 6</a>					
		$C_L = 15\text{ pF}$	1.0	-	10.0	ns	
		$C_L = 50\text{ pF}$	1.0	-	12.5	ns	

[1] Typical values are measured at  $V_{CC} = 3.3\text{ V}$ .

[2] Typical values are measured at  $V_{CC} = 5.0\text{ V}$ .

[3]  $C_{PD}$  is used to determine the dynamic power dissipation ( $P_D$  in  $\mu\text{W}$ ).

$P_D = C_{PD} \times V_{CC}^2 \times f_i \times N + \sum (C_L \times V_{CC}^2 \times f_o)$  where:

$f_i$  = input frequency in MHz;

$f_o$  = output frequency in MHz;

$C_L$  = output load capacitance in pF;

$V_{CC}$  = supply voltage in V;

$N$  = number of inputs switching;

$\sum (C_L \times V_{CC}^2 \times f_o)$  = sum of outputs.

[4] The condition is  $V_i = GND$  to  $V_{CC}$ .

**Table 10: Dynamic characteristics type 74AHCT132**

$GND = 0\text{ V}$ ;  $t_r = t_f \leq 3.0\text{ ns}$ ; for test circuit see [Figure 7](#).

Symbol	Parameter	Conditions	Min	Typ	Max	Unit
<b><math>T_{amb} = 25\text{ °C}</math> [1]</b>						
$t_{PHL}$ , $t_{PLH}$	propagation delay nA, nB to nY	$V_{CC} = 4.5\text{ V to }5.5\text{ V}$ ; see <a href="#">Figure 6</a> $C_L = 15\text{ pF}$	-	3.5	7.0	ns
		$C_L = 50\text{ pF}$	-	5.0	8.0	ns
$C_{PD}$	power dissipation capacitance	$C_L = 50\text{ pF}$ ; $f = 1\text{ MHz}$	[2] [3]	14	-	pF
<b><math>T_{amb} = -40\text{ °C to }+85\text{ °C}</math></b>						
$t_{PHL}$ , $t_{PLH}$	propagation delay nA, nB to nY	$V_{CC} = 4.5\text{ V to }5.5\text{ V}$ ; see <a href="#">Figure 6</a> $C_L = 15\text{ pF}$	1.0	-	8.0	ns
		$C_L = 50\text{ pF}$	1.0	-	9.0	ns
<b><math>T_{amb} = -40\text{ °C to }+125\text{ °C}</math></b>						
$t_{PHL}$ , $t_{PLH}$	propagation delay nA, nB to nY	$V_{CC} = 4.5\text{ V to }5.5\text{ V}$ ; see <a href="#">Figure 6</a> $C_L = 15\text{ pF}$	1.0	-	9.0	ns
		$C_L = 50\text{ pF}$	1.0	-	10.0	ns

[1] Typical values are measured at  $V_{CC} = 5.0\text{ V}$ .

[2]  $C_{PD}$  is used to determine the dynamic power dissipation ( $P_D$  in  $\mu\text{W}$ ).

$$P_D = C_{PD} \times V_{CC}^2 \times f_i \times N + \sum (C_L \times V_{CC}^2 \times f_o) \text{ where:}$$

$f_i$  = input frequency in MHz;

$f_o$  = output frequency in MHz;

$C_L$  = output load capacitance in pF;

$V_{CC}$  = supply voltage in V;

$N$  = number of inputs switching;

$\sum (C_L \times V_{CC}^2 \times f_o)$  = sum of outputs.

[3] The condition is  $V_I = GND$  to  $V_{CC}$ .

## 12. Waveforms

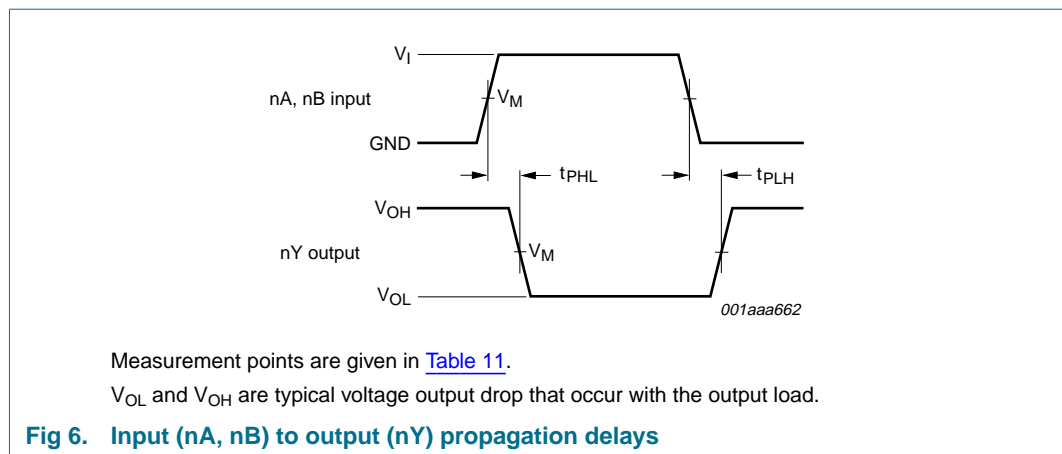

**Table 11: Measurement points**

Type	Input	Output
	$V_M$	$V_M$
74AHC132	$0.5V_{CC}$	$0.5V_{CC}$
74AHCT132	1.5 V	$0.5V_{CC}$

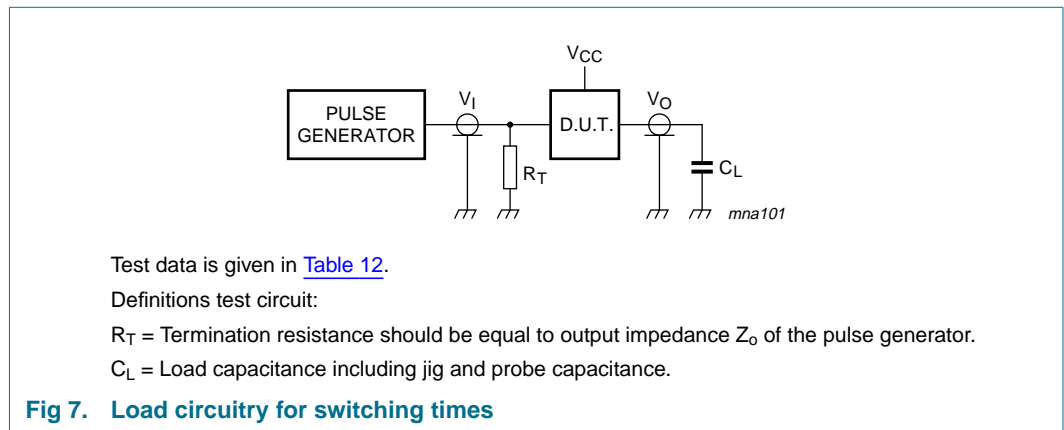

**Table 12: Test data**

Type	Input		Load	Test
	$V_I$	$t_r, t_f$	$C_L$	
74AHC132	$V_{CC}$	$\leq 3.0$ ns	50 pF, 15 pF	$t_{PLH}, t_{PHL}$
74AHCT132	3.0 V	$\leq 3.0$ ns	50 pF, 15 pF	$t_{PLH}, t_{PHL}$

## 13. Transfer characteristics waveforms

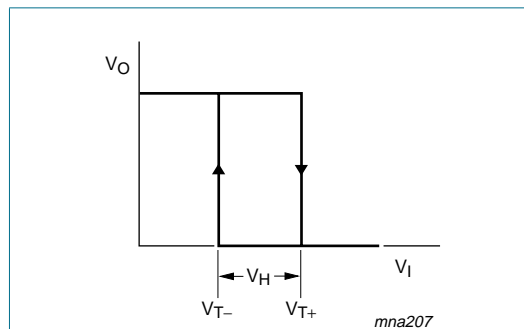

**Fig 8. Transfer characteristics**

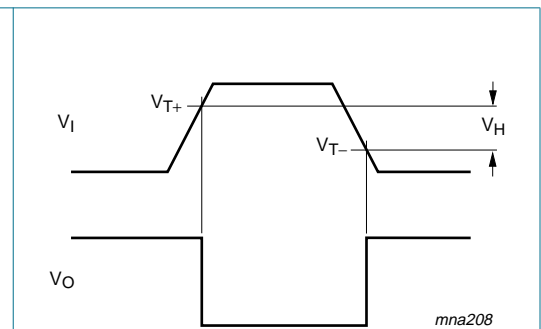

**Fig 9. Definition of  $V_{T+}$ ,  $V_{T-}$  and  $V_H$**

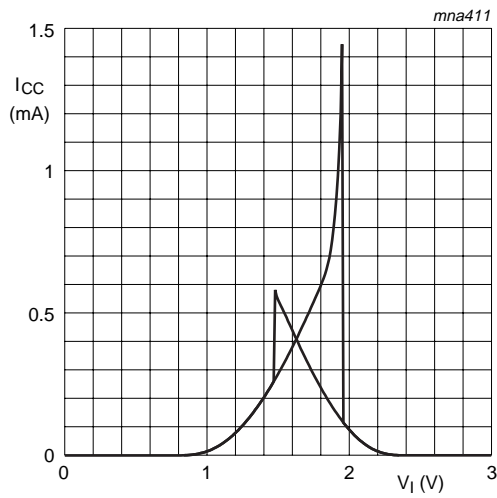

a.  $V_{CC} = 3.0\text{ V}$

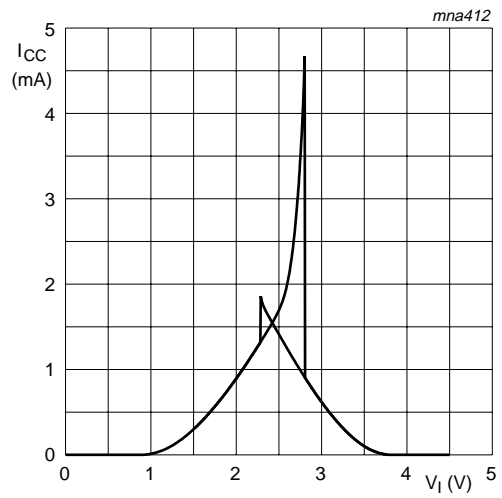

b.  $V_{CC} = 4.5\text{ V}$

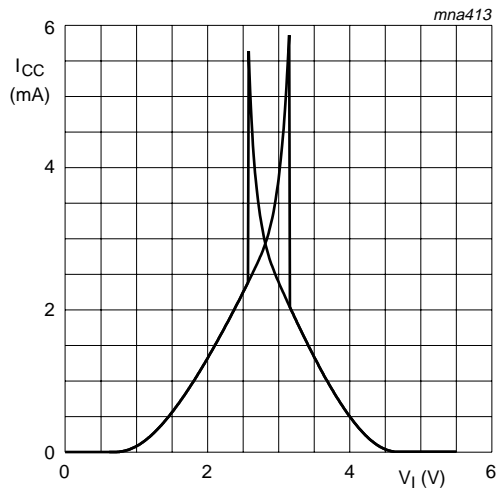

c.  $V_{CC} = 5.5\text{ V}$

Fig 10. Typical 74AHC132 transfer characteristics

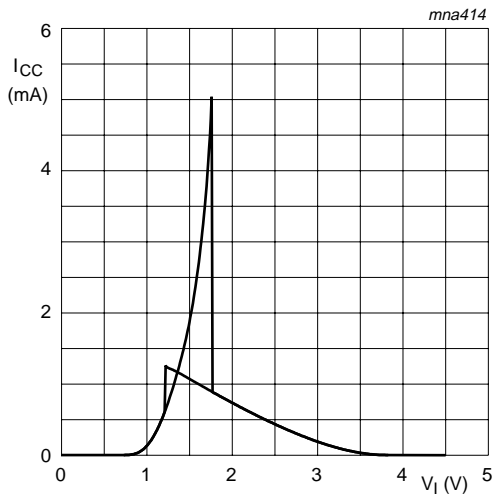

a.  $V_{CC} = 4.5 \text{ V}$ .

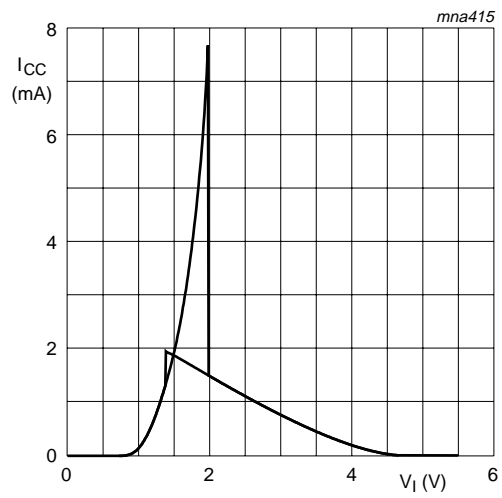

b.  $V_{CC} = 5.5 \text{ V}$ .

Fig 11. Typical 74AHCT132 transfer characteristics

## 14. Application information

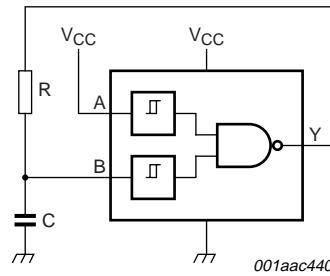

For 74AHC132:  $f = \frac{1}{T} \approx \frac{1}{0.55 \times RC}$  and for 74AHCT132:  $f = \frac{1}{T} \approx \frac{1}{0.60 \times RC}$

Fig 12. Relaxation oscillator

15. Package outline

SO14: plastic small outline package; 14 leads; body width 3.9 mm

SOT108-1

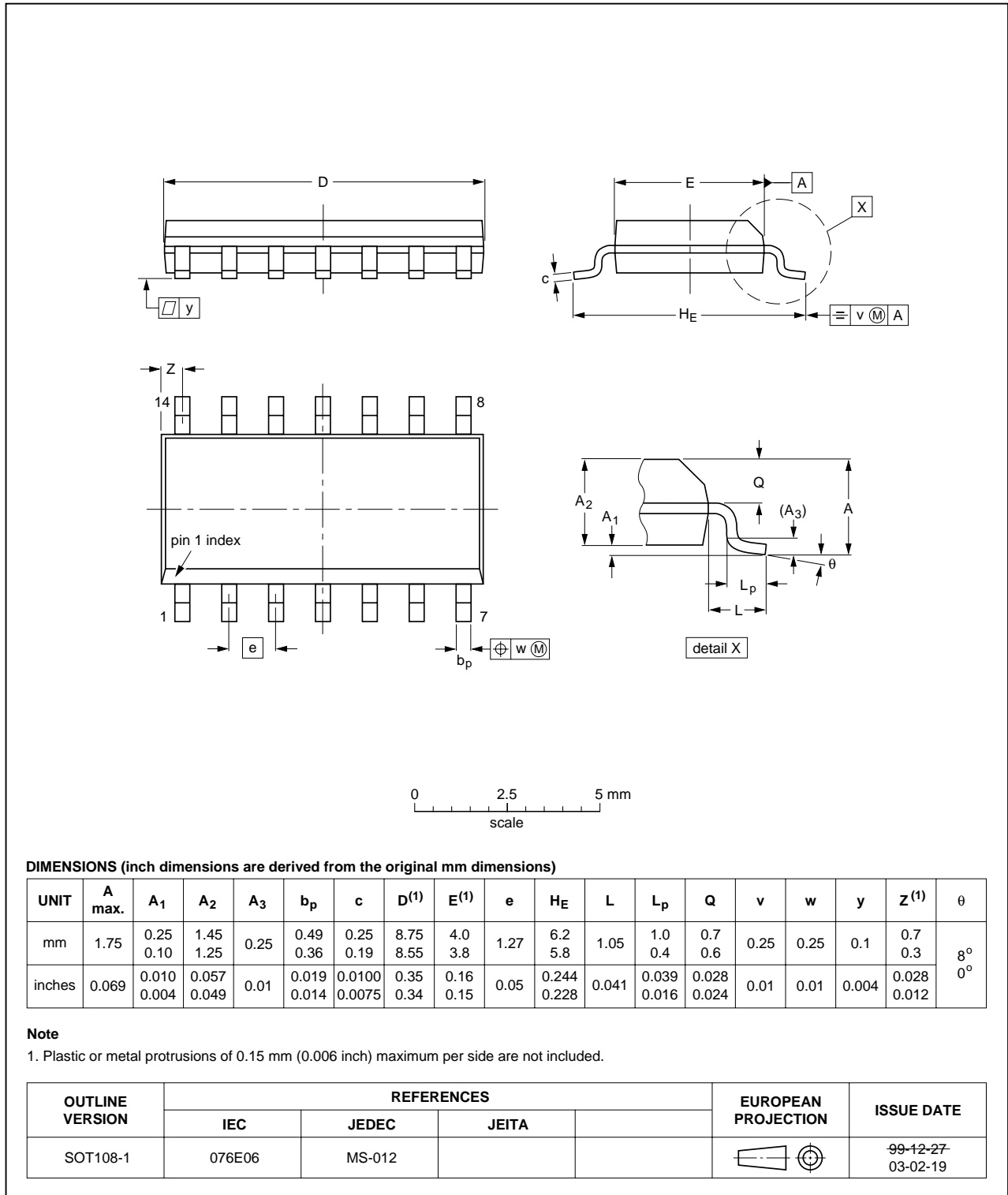

Fig 13. Package outline SOT108-1 (SO14)

TSSOP14: plastic thin shrink small outline package; 14 leads; body width 4.4 mm

SOT402-1

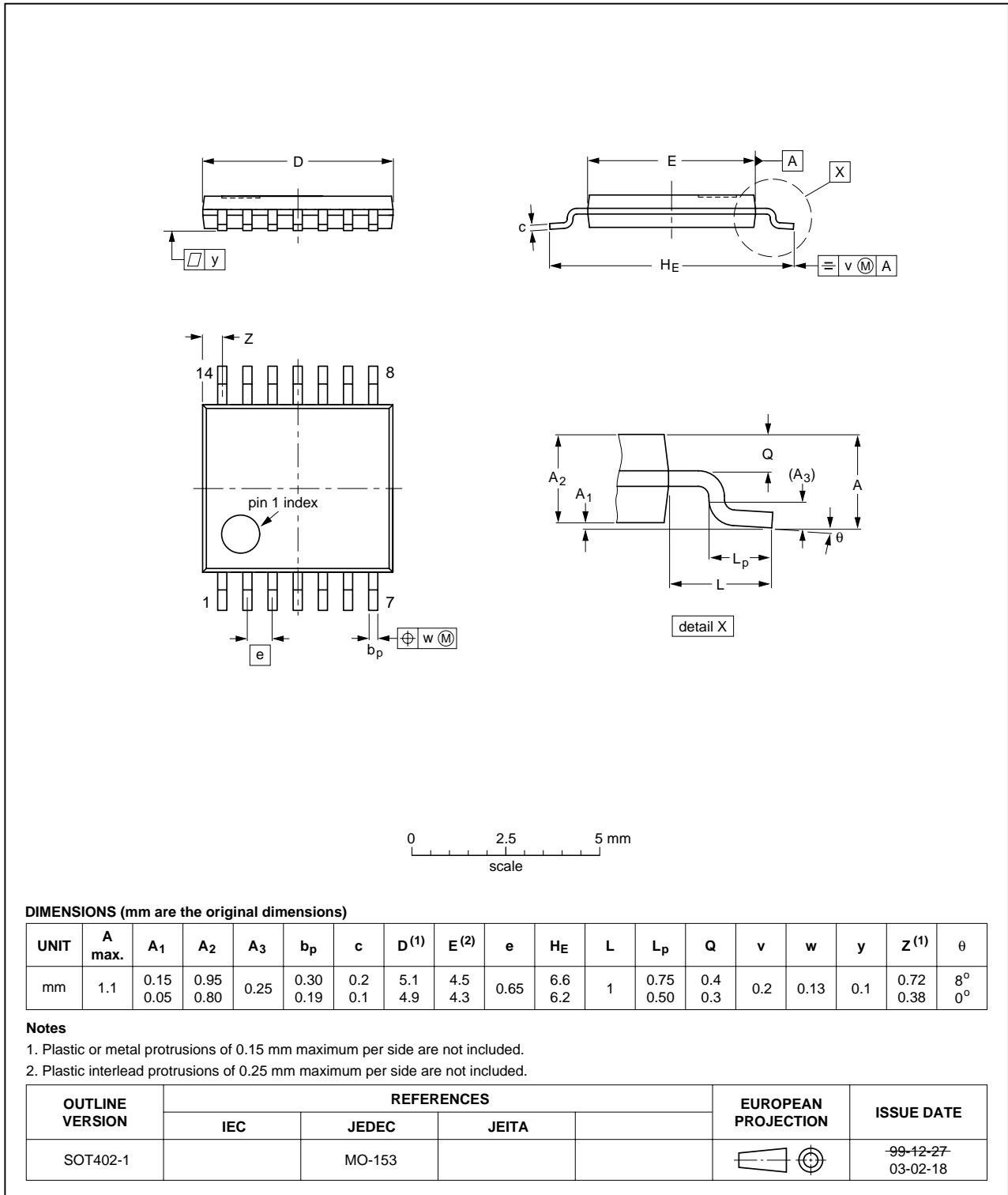

Fig 14. Package outline SOT402-1 (TSSOP14)



DHVQFN14: plastic dual in-line compatible thermal enhanced very thin quad flat package; no leads; 14 terminals; body 2.5 x 3 x 0.85 mm

SOT762-1

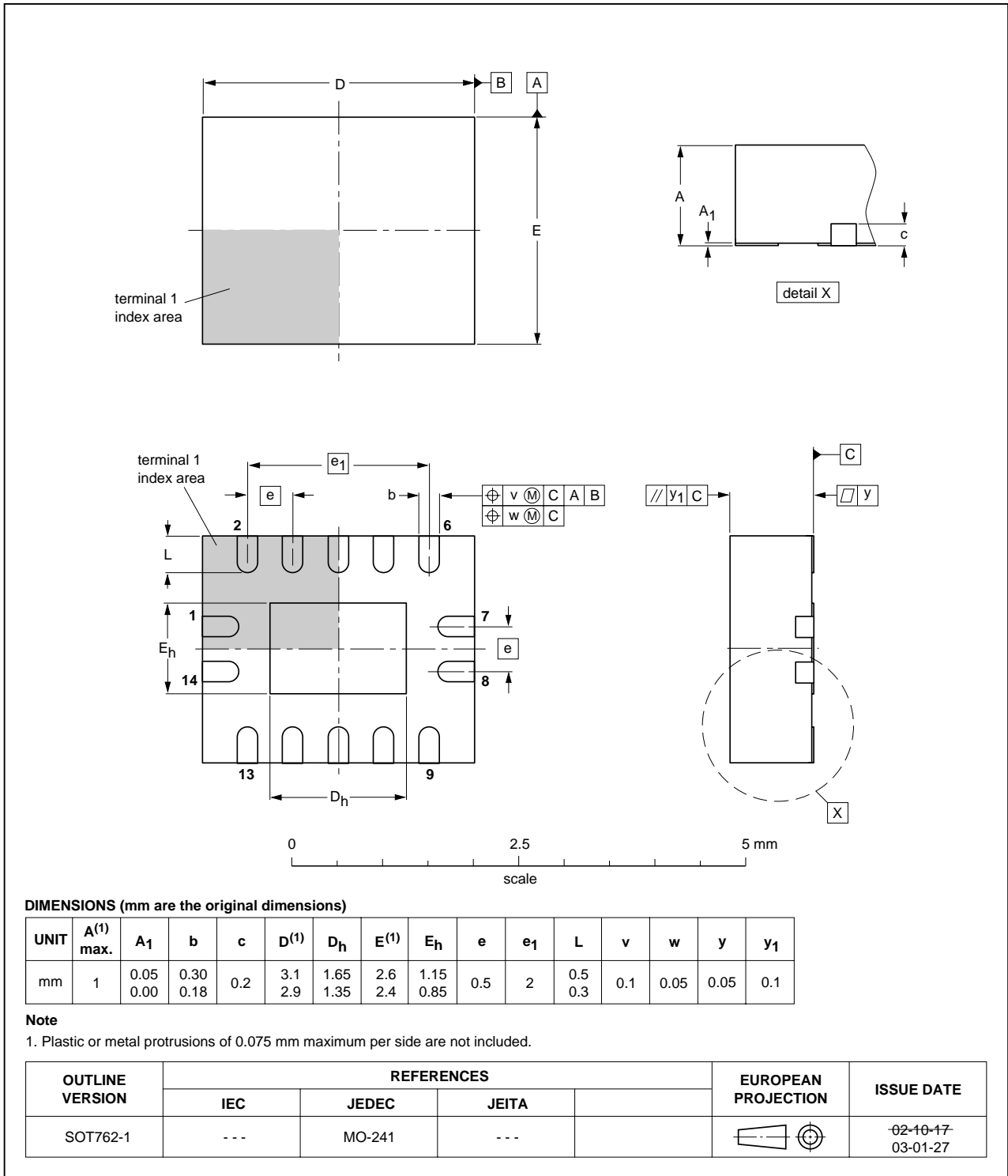

Fig 15. Package outline SOT762-1 (DHVQFN14)

## 16. Revision history

**Table 13: Revision history**

Document ID	Release date	Data sheet status	Change notice	Doc. number	Supersedes
74AHC_AHCT132_4	20050207	Product data sheet	-	9397 750 14505	74AHC_AHCT132_3
Modifications:					
					<ul style="list-style-type: none"><li>• The format of this data sheet is redesigned to comply with the current presentation and information standard of Philips Semiconductors</li><li>• Added: type numbers 74AHC132BQ and 74AHCT132BQ (DHVQFN14 package)</li></ul>
74AHC_AHCT132_3	20040415	Product specification	-	9397 750 13051	74AHC_AHCT132_2
74AHC_AHCT132_2	19990924	Product specification	-	9397 750 06294	74AHC_AHCT132_1
74AHC_AHCT132_1	19990531	Product specification	-	9397 750 05748	-

## 17. Data sheet status

Level	Data sheet status <sup>[1]</sup>	Product status <sup>[2]</sup> <sup>[3]</sup>	Definition
I	Objective data	Development	This data sheet contains data from the objective specification for product development. Philips Semiconductors reserves the right to change the specification in any manner without notice.
II	Preliminary data	Qualification	This data sheet contains data from the preliminary specification. Supplementary data will be published at a later date. Philips Semiconductors reserves the right to change the specification without notice, in order to improve the design and supply the best possible product.
III	Product data	Production	This data sheet contains data from the product specification. Philips Semiconductors reserves the right to make changes at any time in order to improve the design, manufacturing and supply. Relevant changes will be communicated via a Customer Product/Process Change Notification (CPCN).

[1] Please consult the most recently issued data sheet before initiating or completing a design.

[2] The product status of the device(s) described in this data sheet may have changed since this data sheet was published. The latest information is available on the Internet at URL <http://www.semiconductors.philips.com>.

[3] For data sheets describing multiple type numbers, the highest-level product status determines the data sheet status.

## 18. Definitions

**Short-form specification** — The data in a short-form specification is extracted from a full data sheet with the same type number and title. For detailed information see the relevant data sheet or data handbook.

**Limiting values definition** — Limiting values given are in accordance with the Absolute Maximum Rating System (IEC 60134). Stress above one or more of the limiting values may cause permanent damage to the device. These are stress ratings only and operation of the device at these or at any other conditions above those given in the Characteristics sections of the specification is not implied. Exposure to limiting values for extended periods may affect device reliability.

**Application information** — Applications that are described herein for any of these products are for illustrative purposes only. Philips Semiconductors make no representation or warranty that such applications will be suitable for the specified use without further testing or modification.

## 19. Disclaimers

**Life support** — These products are not designed for use in life support appliances, devices, or systems where malfunction of these products can reasonably be expected to result in personal injury. Philips Semiconductors customers using or selling these products for use in such applications do so at their own risk and agree to fully indemnify Philips Semiconductors for any damages resulting from such application.

**Right to make changes** — Philips Semiconductors reserves the right to make changes in the products - including circuits, standard cells, and/or software - described or contained herein in order to improve design and/or performance. When the product is in full production (status 'Production'), relevant changes will be communicated via a Customer Product/Process Change Notification (CPCN). Philips Semiconductors assumes no responsibility or liability for the use of any of these products, conveys no license or title under any patent, copyright, or mask work right to these products, and makes no representations or warranties that these products are free from patent, copyright, or mask work right infringement, unless otherwise specified.

## 20. Contact information

For additional information, please visit: <http://www.semiconductors.philips.com>

For sales office addresses, send an email to: [sales.addresses@www.semiconductors.philips.com](mailto:sales.addresses@www.semiconductors.philips.com)

## 21. Contents

1	General description . . . . .	1
2	Features . . . . .	1
3	Quick reference data . . . . .	1
4	Ordering information . . . . .	2
5	Functional diagram . . . . .	3
6	Pinning information . . . . .	4
6.1	Pinning . . . . .	4
6.2	Pin description . . . . .	4
7	Functional description . . . . .	5
8	Limiting values . . . . .	5
9	Recommended operating conditions . . . . .	5
10	Static characteristics . . . . .	6
11	Dynamic characteristics . . . . .	10
12	Waveforms . . . . .	12
13	Transfer characteristics waveforms . . . . .	13
14	Application information . . . . .	14
15	Package outline . . . . .	15
16	Revision history . . . . .	18
17	Data sheet status . . . . .	19
18	Definitions . . . . .	19
19	Disclaimers . . . . .	19
20	Contact information . . . . .	19



© Koninklijke Philips Electronics N.V. 2005

All rights are reserved. Reproduction in whole or in part is prohibited without the prior written consent of the copyright owner. The information presented in this document does not form part of any quotation or contract, is believed to be accurate and reliable and may be changed without notice. No liability will be accepted by the publisher for any consequence of its use. Publication thereof does not convey nor imply any license under patent- or other industrial or intellectual property rights.

Date of release: 7 February 2005  
Document number: 9397 750 14505

Published in The Netherlands